

DEPARTMENT OF THE ARMY TECHNICAL MANUAL

**OPERATOR'S AND ORGANIZATIONAL  
MAINTENANCE MANUAL  
SUPPRESSOR, ELECTRICAL TRANSIENT MX-7778/GRC  
(NSN 5915-00-937-9564)**

Headquarter, Department of the Army, Washington, DC  
5 May 1971

**WARNING**

**HIGH AMPERAGE CURRENT FLOWS IN AND OUT OF SUPPRESSOR,  
ELECTRICAL TRANSIENT MX-7778/GRC**

Short circuits involving these currents can cause serious burns to personnel and a welding or burning effect on plugs and connectors.

	Paragraph	Page
CHAPTER 1. INTRODUCTION		
SECTION I. General		
Scope .....	1-1	1-1
Indexes of publications .....	1-2	1-1
Forms and records .....	1-3	1-1
Reporting of errors .....	1-3.1	1-1
Reporting equipment improvement recommendations (EIR) .....	1-3.2	1-1
Administrative storage .....	1-3.3	1-1
Destruction of Army electronics materiel .....	1-3.4	1-1
II. Data		
Purpose and use .....	1-4	1-1
Technical characteristics .....	1-5	1-1
Description .....	1-6	1-2
Items comprising an operable equipment .....	1-7	1-2
CHAPTER 2. INSTALLATION AND OPERATION		
Checking equipment .....	2-1	2-1
Installing MX-7778/GRC .....	2-2	2-1
Operating instructions .....	2-3	2-1
3. OPERATOR'S MAINTENANCE		
Scope of operator's maintenance .....	3-1	3-1
Operator's preventive maintenance .....	3-2	3-1
Preventive maintenance checks and services periods .....	3-3	3-1
Cleaning .....	3-4	3-2
4. ORGANIZATIONAL MAINTENANCE		
Scope of organizational maintenance .....	4-1	4-1
Tools and materials required .....	4-2	4-1
Organizational preventive maintenance .....	4-3	4-1
Preservation .....	4-4	4-1
Organizational Troubleshooting and Repairs .....	4-5	4 1
CHAPTER 5. ADMINISTRATIVE STORAGE		
General .....	5-1	5-1
Administrative storage procedures .....	5.2	5-1
APPENDIX A. REFERENCES .....		A-1
B. MAINTENANCE ALLOCATION		
SECTION I. Introduction .....		B-1
II. Maintenance allocation chart .....		B-3
III. Tool and test equipment requirements .....		B-4
IV. Remarks .....		B-5

\*This manual supersedes TM 11-5915-223-12,21 January 1969, including all changes.

	Paragraph	Page
APPENDIX C. COMPONENTS OF END ITEM LIST		
SECTION I. Introduction		
II. Integral components of end item for Suppressor		
Electrical Transient (MX-7778/GRC)		C-3
III. Basic issue items		C-4
APPENDIX D. ADDITIONAL AUTHORIZATION LIST (NOT APPLICABLE)		
E. EXPENDABLE SUPPLIES AND MATERIALS LIST		
SECTION I. Introduction		E-1
II. Expendable Supplies and Materials List		E-3

CHANGE

No. 6

HEADQUARTERS  
DEPARTMENT OF THE ARMY  
WASHINGTON, DC, 1 January 1989

OPERATOR'S AND ORGANIZATIONAL  
MAINTENANCE MANUAL  
SUPPRESSOR, ELECTRICAL TRANSIENT MX-7778/GRC  
(NSN 5915-00-937-9564)

TM 11-5915-223-12, 5 May 1971, is changed as follows:

1. Remove old pages and insert new pages as indicated below. New or changed material is indicated by a vertical bar in the margin of the page. Added or revised illustrations are indicated by a vertical bar adjacent to the identification number or by a pointing hand on the illustration page.

<u>Remove pages</u>	<u>Insert pages</u>
4-1 and 4-2.....	4-1 and 4-2

2. File this change sheet in front of the publication for reference purposes.

**Distribution authorized to the Department of Defense and DOD contractors only for official use or for administration or operational purposes. This determination was made on 5 July 1988. Other requests for this document will be referred to Commander, US Army Communications-Electronics Command and Fort Monmouth, ATTN: AMSEL-LC-ME-P, Fort Monmouth, NJ 07703-5000.**

**DESTRUCTION NOTICE — Destroy by any method that will prevent disclosure of contents or reconstruction of the document.**

By Order of the Secretary of the Army:

CARL E. VUONO  
General, United States Army  
Chief of Staff

Official:

WILLIAM J. MEEHAN II  
Brigadier General, United States Army  
The Adjutant General

DISTRIBUTION:

To be distributed in accordance with DA Form 12-51 Operator and  
Unit requirements for MX-7778/GRC.



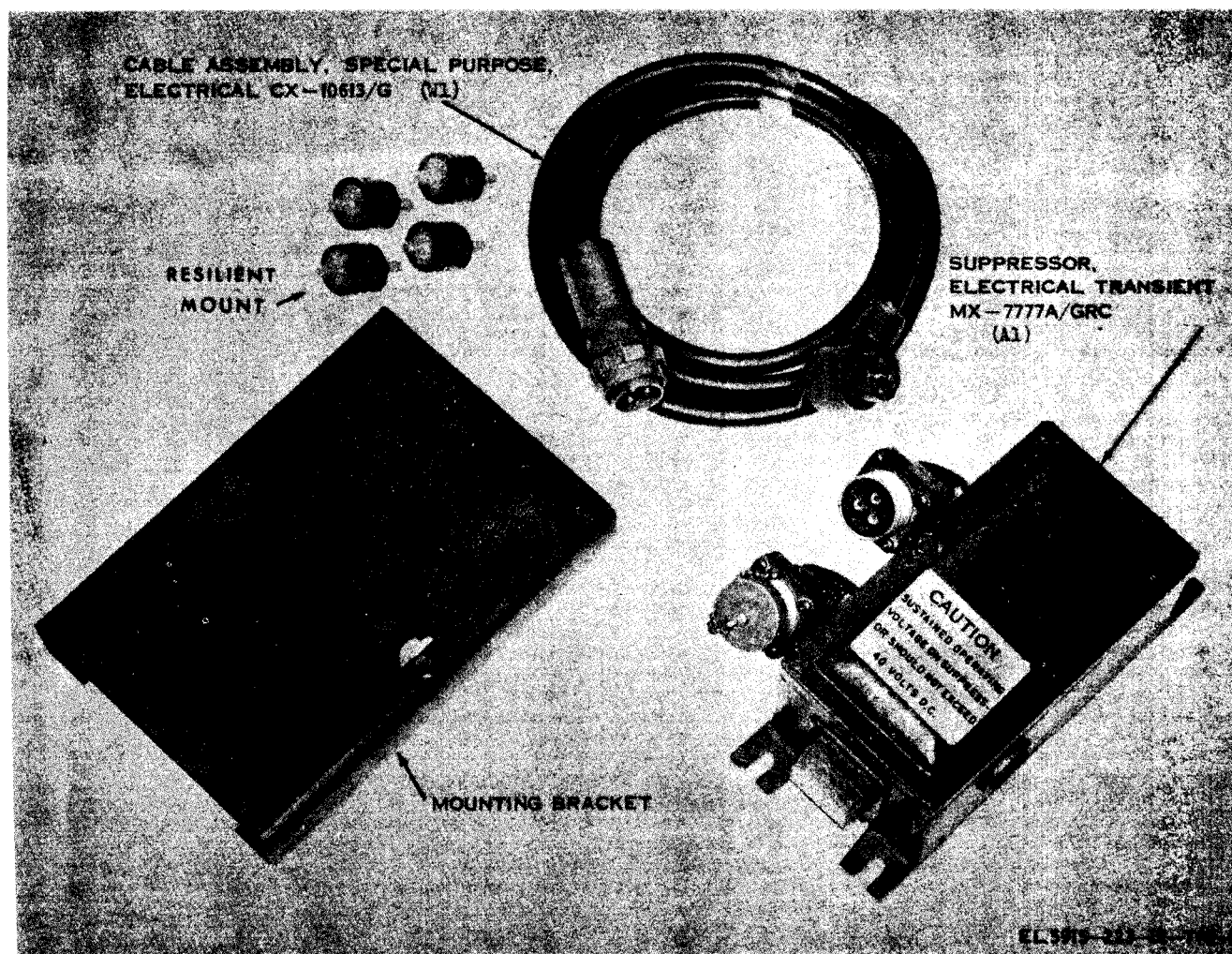

Figure 1-1. Suppressor, Electrical Transient MX 7778/GRC.

**CHAPTER 1**  
**INTRODUCTION**

---

**Section I. GENERAL**

1-1. scope

a. This manual provides installation, operation, and organizational maintenance instructions for Suppressor, Electrical Transient MX-7778/GRC. Throughout this manual, Suppressor, Electrical Transient MX-7778/GRC will be referred to as the suppressor.

b. The maintenance allocation chart (MAC) is in appendix B.

1-2. Indexes of Publications

a. DA Pam 310-4. Refer to the latest issue of DA Pam 310-4 to determine whether there are new editions, changes, or additional publications pertaining to the equipment.

b. DA Pam 310-7. Refer to the latest issue of DA Pam 310-7 to determine whether there are modification work orders (MWO'S) pertaining to the equipment.

1-3. Forms and Records

a. *Reports of Maintenance and Unsatisfactory Equipment.* Maintenance forms, records, and reports which are to be used by maintenance personnel at all maintenance levels are listed in and prescribed by TM 38-750.

b. *Report of Packaging and Handling Deficiencies.* Fill out and forward DD Form 6 (Packaging Improvement Report as prescribed in AR 700-58 NAVSUPINST 4030.29/AFR 71-13/MCOP-4030.29A, and DLAR 4145.8.

c. *D iscrepancy in Shipment Report (DISREP) (SF 361).* Fill out and forward Discrepancy in Shipment Report (DISREP) (SF 361) as prescribed

in AR 55-38/NAVSUPINST 4610.33B/AFR 75-181 MCO P4610.19C, and DLAR 4500.15.

1-3.1. Reporting of Errors

The reporting of errors, omissions, and recommendations for improving this publication by the individual user is encouraged. Reports should be submitted on DA Form 2028 (Recommended Changes to Publications and Blank Forms) and forwarded direct to Commander, US Army Communications and Electronics Materiel Readiness Command, ATTN: DRSEL-ME-MQ, Fort Monmouth, NJ 07703.

1-3.2. Reporting Equipment Improvement Recommendations (EIR)

EIR's will be prepared using Standard Form 368, Quality Deficiency Report. Instructions for preparing EIR's are provided in TM 38-750, The Army Maintenance Management System. EIR's should be mailed direct to Commander, US Army Communications and Electronics Materiel Readiness Command, ATTN: DRSEL-ME-MQ, Fort Monmouth, New Jersey 07703. A reply will be furnished direct to you.

1-3.3. Administrative Storage

Administrative storage of equipment issued to and used by Army activities shall be in accordance with chapter 5.

1-3.4. Destruction of Army Electronics Materiel

Destruction of Army electronics materiel to prevent enemy use shall be in accordance with TM 750-244-2.

**Section II. DATA**

1-4. Purpose and Use

a. *Purpose.* The suppressor prevents the high-voltage electrical transients (spikes) in a direct current (dc) power electrical system from being applied to transistorized radios. The suppressor also prevents the transposed direct current potential from being applied to the transistorized radios, which occurs when the cable connection to the dc power source is inadvertently transposed; that is, the negative and positive leads are connected to the positive and negative, respectively, terminals of the dc power source.

b. *Use.* The suppressor is normally installed in a vehicle between the dc power electrical system and transistorized radios (fig. 2-2).

(1) Typical examples of transistorized radio sets that this suppressor may be used with are -

(a) Radio Sets AN/VRC-12 and AN/VRC-43 through AN/VRC-49 (TM 11-5820-401-10-1),

(b) Radio Sets AN/GRC-106 and AN/GRC-106A (TM 11-5820-520-12).

(c) Radio Sets AN/VRC-53, AN/VRC-64, AN/GRC-125, and AN/GRC-160 (TM 11-5820-498-12).

(2) More than one radio set may be connected to the suppressor as long as the total current drain for the radios does not exceed 50 amperes (1,400 watts at 28 volts de).

1-5. Technical Characteristics

- Input voltage 22- to 28-volt dc power source: normally vehicular electrical system.
- Maximum input voltage ..... Approximately 40 volts dc.
- Output voltage ..... Same as input voltage.
- Output load ..... Transistorized radio sets (para 1-4b).
- Electrical suppression ..... Electrical transients (spikes) dc power source system in excess of approximately 36 volts are prevented from being applied to output load.
- Overload and short circuit protection ..... 50-ampere circuit breakers.
- Transposed dc input voltage ..... Transposed voltage is prevented from being applied to output load.
- Internal diode overheating protection ..... Thermostat switch and 50 ampere circuit breakers. Requires two minutes for diode to cool.

1-6. Description  
(fig. 1-1)

The suppressor consists of Cable Assembly, Special Purpose, Electrical CX-10613/G, Suppressor, Electrical Transient MX-7777A/GRC, and the mounting bracket. The MX-7777A/GRC has one control for the ganged circuit breakers (fig. 4-1), two connectors mounted on one side for the load (one is provided with a cover), and one connector mounted on the opposite side for the power input through the CX-10613/G. The parts in the MX-7777A/GRC which comprise the protective circuit for the load are the ganged circuit breakers, the zener diode, and a thermostatic switch. The cover to the MX-7777A/GRC is secured by screws. The MX-7777A/GRC thermostatic switch is shown in figure 4-1.

1-7. Items Comprising an Operable Equipment  
(fig. 1-1)

The items in table 1-1 below make up an operable MX-7778/GRC. One copy of TM 11-5915-223-12 is packed with each MX-777/GRC.

Table 1-1. Items Comprising an Operable Equipment

NSN	Item	Quantity	Length	Width (in.)	Depth (in.)	Weight (lb.)
5915-00-937-9577	Suppressor, Electrical Transient MX-7777A/GRC.	1	10.187 in.	6.343	5.25	10
5995-00-935-2551	Cable Assembly, Special Purpose Electrical CX-10613/G. Mounting bracket, including bag of mounting hardware screws, washer, nuts, ground strap, and four shock mounts.	1	10.0 ft.			2¾
	Template, hole .....	1				*4¾

\*Mounting bracket only.



1-8. Hand Receipt

Hand receipts for End Item/Components of End Item (COEI), Basic Issue Items (BII), and Additional Authorized List (AAL) items are published in a Hand Receipt Manual. The Hand Receipt Manual numerical designation is the same as the related Technical Manual

with the letters HR added to the number. These manuals are published to aid in property accountability and are available through: Commander, US Army Adjutant General Publication Center, ATTN: AGDL-OD, 1655 Woodson Road, St, Louis, MO 63114.



**CHAPTER 2**  
**INSTALLATION AND OPERATION**

### 2-1. Checking Equipment

(fig. 2-1)

a. Check to see that the equipment is complete as listed on the packing slip. If the packing slip is not available, check the equipment against the list in table 1-1.

**NOTE**

Shortage of a minor assembly or part that does not affect proper functioning of the equipment should not prevent use of the equipment.

b. Inspect the equipment for damage. If the equipment has been damaged during shipment, refer to paragraph 1-3.

c. Keep the circuit breaker in the off position during installation until the radio sets are to be turned on.

### 2-2. Installing MX-7778/GRC

(fig. 2-2)

When installing the mounting bracket in a vehicle, select a place where the following can be accomplished within the space limits of the vehicle.

a. The MX-7777A/GRC circuit breaker is readily accessible.

b. Cables are easily attached or removed.

c. The four nuts that secure the mounting feet on the MX-7777A/GRC resilient mounts and the nuts that secure the resilient mounts to the mounting bracket are accessible for removal or replacement of the MX-7777A/GRC.

d. A typical installation for the suppressor is shown in figure 2-2. Use the hole template (provided with a new MX-7778/GRC), or use the holes in the mounting bracket to determine the position of the holes to be drilled in the surface to which the mounting bracket is to be attached.

### 2-3. Operating Instructions

a. Be sure that the input and output cables are properly connected. Set the circuit breakers to the on position to complete the circuit. On for the circuit breakers is in the up position, and off is in the down position. The power can then be applied from the vehicular power supply to the load.

b. The suppressor is now functioning and, if the transient voltage exceeds approximately 36 volts, the suppressor will limit the voltage to the load at

that level. If the circuit breakers open, long-term transients are present, or severe malfunctioning of the vehicular power supply is occurring and should be checked. The circuit breakers will also open if too much current is being drawn by the load.

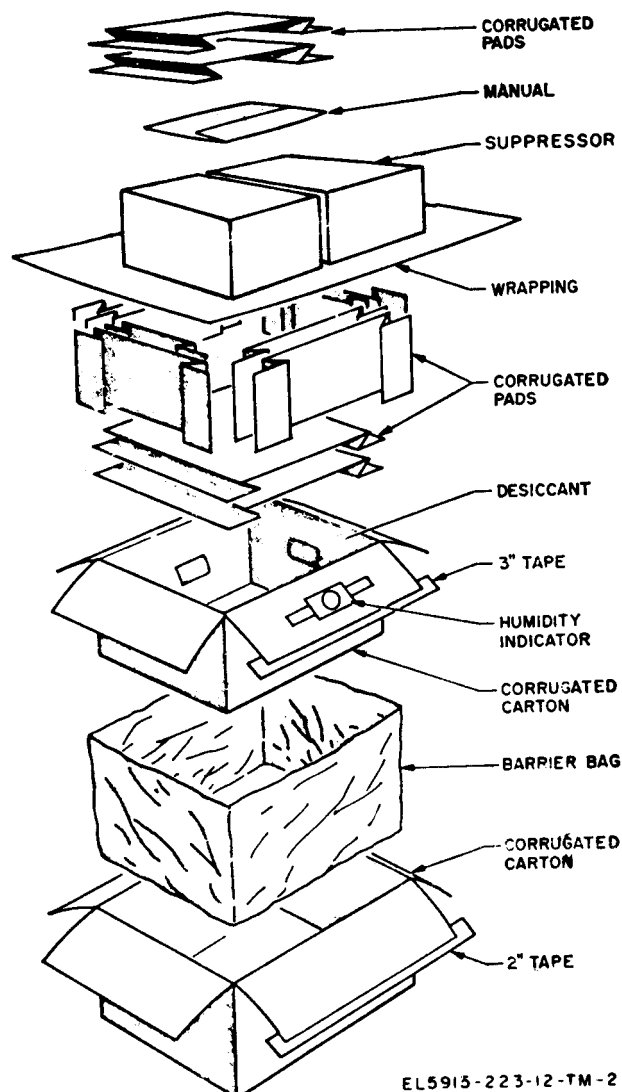

EL5915-223-12-TM-2

Figure 2-1. Suppressor, Electrical Transient MX-7778/GRC packaging.

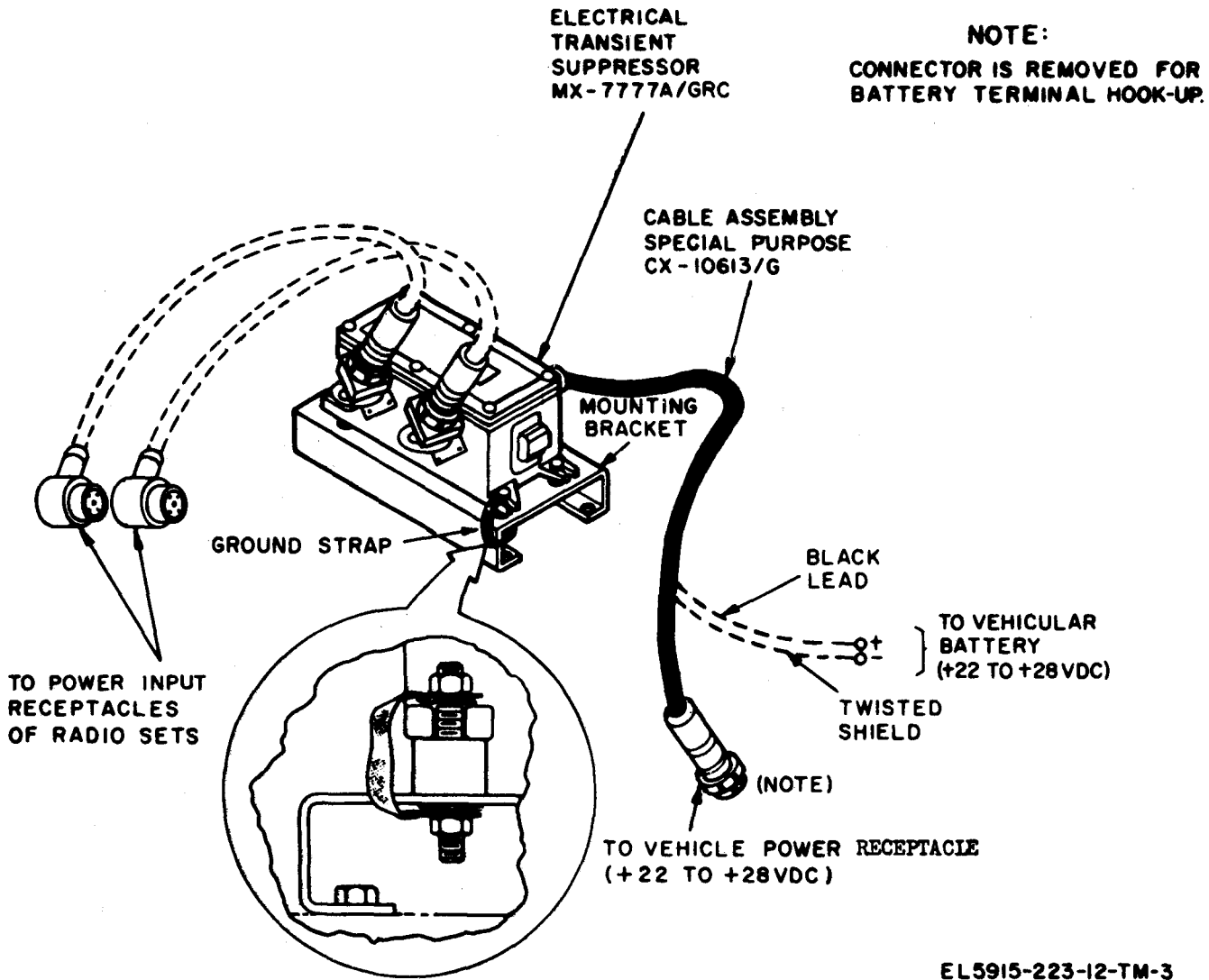

Figure 2-2. Typical installation.

**CHAPTER 3  
OPERATOR'S MAINTENANCE**

**3-1. Scope of Operator's Maintenance**

The following is a list of maintenance duties normally performed by the operator. These procedures do not require any tools or test equipment; however, some cleaning materials are required, such as a brush or lint-free cloth. Operator maintenance consists of the following:

- a. Operator's daily preventive maintenance checks and services (table 3-1).
- b. Cleaning (para 3-4).

**3-2. Operator's Preventive Maintenance**

Operator's preventive maintenance is the systematic care, servicing, and inspection of equipment to prevent the occurrence of trouble, to reduce downtime, and to assure that the equipment is serviceable.

a. *Systematic Care.* The procedures given in table 3-1 and paragraph 3-4 cover routine systematic care and cleaning essential for proper equipment operation and maintenance.

b. *Preventive Maintenance Checks and Services.* The preventive maintenance checks and services (table 3-1) outline functions to be performed at specific intervals. These checks and services are to maintain Army electronic equipment in good operating condition. To assist operator's in maintaining combat serviceability, table 3-1 indicates what to check, and how to check the suppressor. Records and reports of these checks and services must be made in accordance with the requirements set forth in TM 38-750.

**NOTES**

BEFORE OPERATION, perform your B PMCS to be sure that your equipment is ready to go.

DURING OPERATION, perform your D PMCS. This should help you spot small troubles before they become big problems.

ROUTINE CHECKS like:

CLEANING, DUSTING, WASHING, CHECKING FOR FRAYED CABLES, STOWING ITEMS NOT IN USE, COVERING UNUSED RECEPTACLES AND CHECKING FOR LOOSE NUTS AND BOLTS are not listed as PMCS checks. They are things that you should do anytime you see they must be done. WHEN YOU ARE DOING ANY PMCS OR ROUTINE CHECKS, KEEP IN MIND THE WARNINGS AND CAUTIONS.

**3-3. Preventive Maintenance Checks and Services Periods**

Preventive maintenance checks and services of the suppressor are required daily. Table 3-1 specifies checks and services that must be accomplished daily, or under the special conditions listed in a, b, and c below.

- a. When equipment is initially installed.
- b. When equipment is reinstalled after removal for any reason.
- c. At least once each week if equipment is maintained in standby condition.

**NOTES**

Before you operate, always keep in mind the CAUTIONS and WARNINGS.

The Item No. Column in table 3-1 shall be used as a source of item numbers for the "TM Number" column on DA Form 2404, Equipment Inspection and Maintenance Worksheet, in recording results of PMCS.

**WARNING**

Large values of current can pass through circuits within MX-7777A/GRC. Careless use of tools or test leads can cause damage to circuits, destruction of test probes, or tools, and injury to personnel.

*Table 3-1. Operator's Daily Preventive Maintenance Checks and Services*

**NOTE**

Within designated interval, these checks are to be performed in the order listed.

B — Before

D — During

Item No.	Interval		Item to be inspected	Procedures Check and have repaired or adjusted as necessary	For readiness reporting equipment is not ready/ available if:
	B	D			
1	*		Exterior surfaces.	Clean exterior surfaces of suppressor (para 3-4).	
2	*		Power cable.	Check condition of power cable insulation and check that plug and connector are properly secured.	

Table 3-1. Operator's Daily Preventive Maintenance Checks and Services

Item No.	Interval		Item to be inspected	Procedures Check and have repaired or adjusted as necessary	For readiness reporting equipment is not ready/ available if:
	B	D			
3	*		screws, cap hex head.	Check screws. Replace missing screws, and tighten any that may have become loose.	
4	*		Circuit breaker control.	With radio sets turned off check the circuit breaker switch for smoothness and ease of operation when moving control to the ON and OFF positions.	
5	*		BATTLE OVERRIDE switch.  The following procedure requires the breaking of radio silence. This manual does not authorize breaking of radio silence imposed by any command. Unauthorized breaking of radio silence could result in court martial or possible death from hostile action.	With radio sets turned off, check for normal operation of BATTLE OVERRIDE switch when moving it to ON and OFF positions.  <b>WARNING</b>	
6	*		Operational check.	Check the operation of the suppressor with the equipment with which it is being used. Do not break radio silence if it is in effect.	

### 3-4. Cleaning (fig. 3-1)

Inspect the exterior of the suppressor. The exterior surfaces must be free of dust, dirt, grease, and fungus.

a. Remove dust and loose dirt with a clean soft cloth.

b. Remove dust or dirt from the connectors with a brush. (Do not disconnect the cables.)

c. Clean the front panel and the circuit breaker guard; use a soft, clean cloth. If dirt is difficult to remove, dampen the cloth with water; use mild soap if necessary.

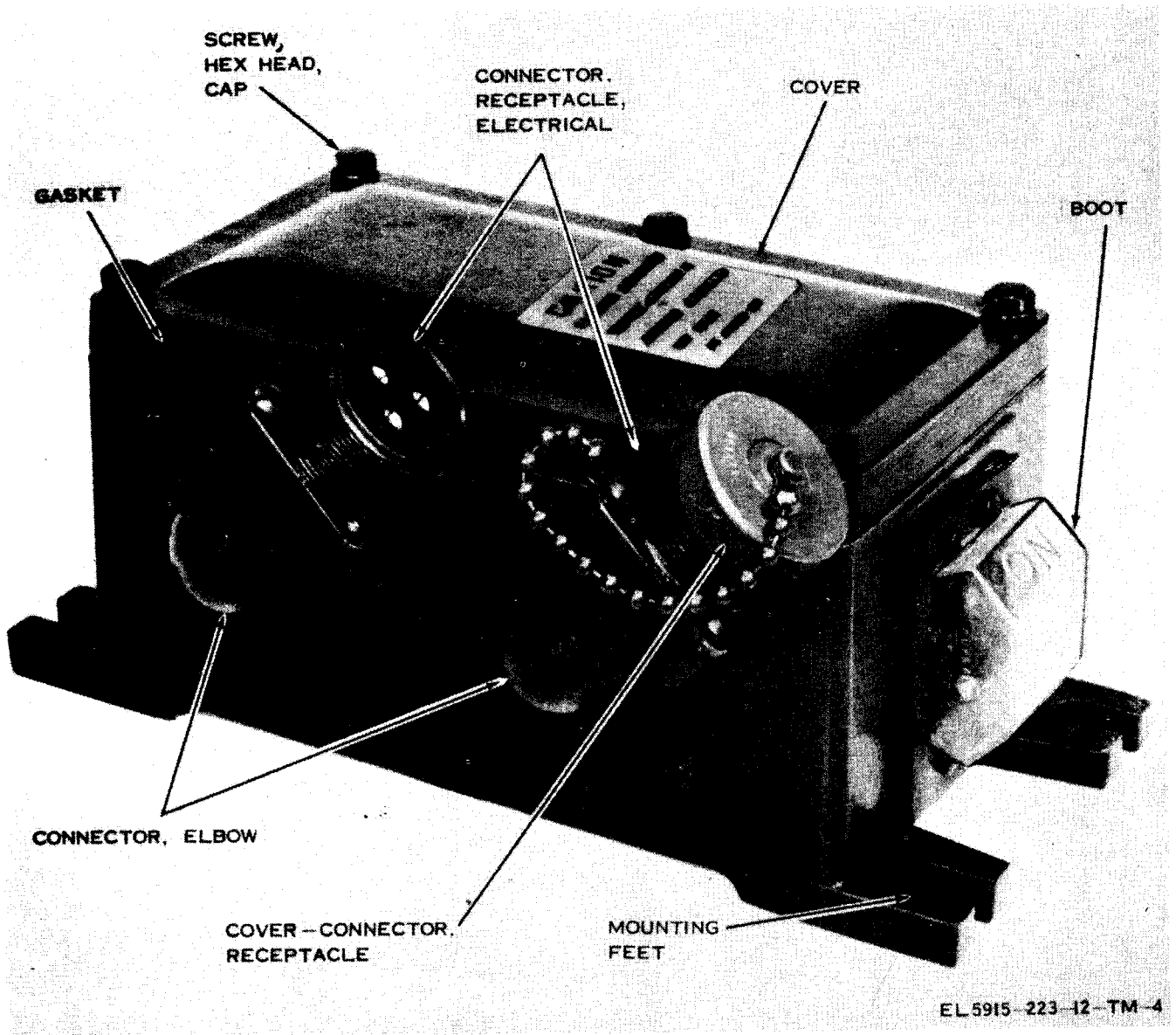

Figure 3-1. Suppressor, Electrical Transient MX-7777A/GRC, diagonal view.





## CHAPTER 4

### ORGANIZATIONAL MAINTENANCE

#### 4-1. Scope of Organizational Maintenance

a. This chapter contains instructions covering organizational maintenance of the suppressor. It includes instructions for performing preventive maintenance services and repair to be accomplished by the organizational maintenance personnel.

b. organizational maintenance of the suppressor includes the following

- (1) Organizational preventive maintenance (para 4-3).
- (2) Organizational quarterly preventive maintenance checks and services (table 4-1).
- (3) reservation (para 4-4).
- (4) Troubleshooting and repair (para 4-5).

#### 4-2. Tools and Materials Required

A list of parts authorized, for organizational maintenance appears in TM 11-5915-223-24P.

a. *Tools.* Tool Kit, Electronic Equipment TK-101/G is authorized for organizational maintenance.

b. *Materials.* See appendix E.

#### 4-3. Organizational Preventive Maintenance

a. Organizational preventive maintenance is the systematic care and inspection of equipment to maintain it in serviceable condition, to prevent breakdown, and to assure maximum operational capability. Preventive maintenance is the responsibility of all categories of maintenance concerned with the equipment. It includes inspection, testing and repair or replacement of parts (as authorized) that inspections and tests indicate would probably fail before the next scheduled periodic service. Preventive maintenance and services of the suppressor at the organizational category of maintenance are made at quarterly intervals, unless otherwise directed by the commanding officer.

b. Maintenance forms and records to be used and maintained on this equipment are specified in TM 38-750.

c. When the quarterly checks and services are performed the daily checks and services also form a part of the quarterly checks and services.

● *Table 4-1. Organizational Quarterly Prevention Maintenance Checks and Services*

Item No.	Item to be inspected	Procedures Check for and have repaired. replaced, adjusted as necessary
1	Installation.	Check to see that the equipment is properly installed.
2	Preservation.	Check surfaces for evidence of fungus. Remove rust and corrosion from metal surfaces by lightly sanding them with fine sandpaper. Brush two thin coats of proper paint on bare metal to protect it from further corrosion (para 4-4).
3	Modifications.	Check to determine whether new applicable MWO's have been published. All URGENT MWO's must be applied immediately. All NORMAL MWO's must be scheduled.
4	Technical manuals.	Check manuals for completeness (app A).
5	Gasket.	Check gasket under MX-7777A/GRC cover for cracks and for evidence of deterioration.
6	MX-7777A/GRC case.	Check MX-7777A/GRC case for evidence of overheating.
7	Connectors.	Check to see that connectors are secured tightly to MX-7777A/GRC case.
8	Dust caps and receptacle connector cover.	Check to see that the dust caps and receptacle connector cover are not missing.
9	Resilient mounts.	Check to see that resilient mounts are not hard, brittle, or cracked.
10	Ground strap.	Check to see that ground strap is securely fastened and makes good contact to the MX-7777A/GRC as shown in figure 2-2.

#### 4-4. Preservation

Remove rust and corrosion from metal surfaces by lightly sanding them with fine sandpaper. Brush two thin coats of paint on the bare metal to protect it from further corrosion. Refer to the applicable cleaning and refinishing practices specified in TB 43-0118.

#### 4-5. Organizational Troubleshooting and Repairs

(fig. 4-1)

Troubleshooting and repair of the suppressor consists of cable substitution and replacement of the MX-7777A/GRC, TM 11-5915-223-24P. The repair or replacement of parts is not authorized by

organizational personnel. Refer these requirements to a higher category of maintenance.

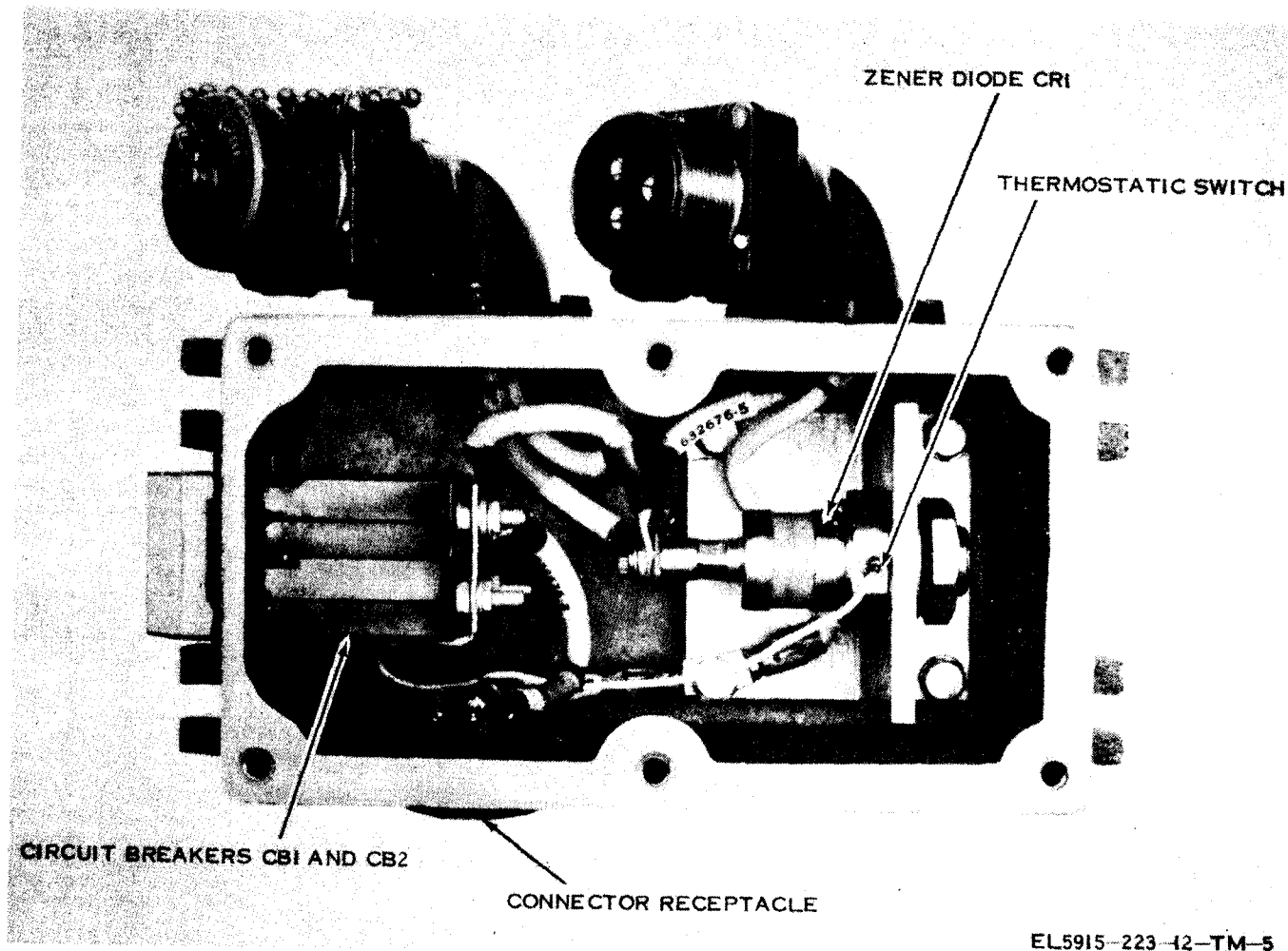

EL5915-223-12-TM-5

Figure 4-1. Suppressor, Electrical Transient MX-777A/GRC, cover removed.

## CHAPTER 5

### ADMINISTRATIVE STORAGE

---

#### 5-1. General

Equipment that will not be used for short periods of time (1 to 45 days) should be put in administrative storage. This procedure will prevent the MX-7778/GRC from being damaged due to unforeseen circumstances.

#### 5-2. Administrative Storage Procedures

The MX-7778/GRC will be placed in administrative storage by performing the following.

a. Perform the operator and organizational preventive maintenance checks and services (PMCS) procedures on the MX-7778/GRC.

b. Remove the MX-7777/GRC from its mount-

ing bracket. The mounting bracket need not be removed as long as the MX-7777A/GRC is to be installed again at the end of the administrative storage period.

c. Disconnect Cable Assembly, Special Purpose, Electrical CX-10613/G and wrap into a neat coil and tie with a suitable string. Place the resilient mounts in a small bag and fasten to the MX-7777A/GRC.

d. Place the MX-7778/GRC in a dry cool room on a suitable shelf.

e. To place the MX-7778/GRC back in operation, install the resilient mounts, the MX-7777A/GRC, the power cable, and perform the PMCS procedures.



## APPENDIX A REFERENCES

The following list of applicable references are available to organizational, general support, and depot maintenance personnel of Electrical Transient Suppressor MX-7778/GRC.

DA Pam 310-4	Index of Technical Manuals, Technical Bulletins, Supply Manuals (Types 7, 8, and 9), Supply Bulletins, and Lubrication Orders.
DA Pam 310-7	US Army Equipment Index of Modification Work Orders.
SB 38-100	Preservation, Packaging, Packing and Marking Materials, Supplies, and Equipment Used by the Army,
SC 5180-91-CL-R07	Sets, Kits, and Outfits Components List, Tool Kit, Electronic Equipment TK-105/G.
SC 5180-90-CL-R13	Sets, Kits, and Outfits Components List, Tool Kit, Electronic Equipment TK-101/G,
SC S180-91-CL-S21	Sets, Kits, and Outfits Components List, Tool Kit, Electronic Equipment TK-100/G.
TB SIG 355-1	Depot Inspection Standard for Repaired Signal Equipment,
TB SIG 355-2	Depot Inspection Standard for Refinishing Repaired Signal Equipment,
TB SIG 355-3	Depot Inspection Standard for Moisture and Fungus Resistant Treatment.
TB 43-0118	Field Instructions for Painting and Preserving Electronic Command Equipment Including Camouflage Pattern Painting of Electrical Equipment Shelter.
TM 11-5915-223-12-HR	Suppressor, Electrical Transient MX-7778/GRC (NSN 5915-00-937-9564).
TM 11-5915-223-24P	Organizational, Direct Support, and General Support Maintenance Repair Parts and Special Tools Lists (Including Depot Maintenance Repair Parts and Special Tools): Suppressor, Electrical Transient MX-7778/GRC. (NSN 5915-00-937-9564).
TM 11-6130-246-12	Operator's and Organizational Maintenance Manual: Power Supply PP-1104C/G (With-Instructions for Use as Battery Charger).
TM 11-6625-200-15	Operator's Organizational, DS, GS, and Depot Maintenance Manual: Multimeters ME-26A, ME-26B/U, ME-26C/U, and ME-26D/U.
TM 38-750	The Army Maintenance Management System (TAMMS).
TM 750-244-2	Procedures for Destruction of Electronics Materiel to Prevent Enemy Use (Electronics Command).



## APPENDIX B MAINTENANCE ALLOCATION

### Section I. INTRODUCTION

#### B-1. General

This appendix provides a summary of the maintenance operations for MX-7778/GRC. It authorizes categories of maintenance for specific maintenance functions on repairable items and components and the tools and equipment required to perform each function. This appendix may be used as an aid in planning maintenance operations.

#### B-2. Maintenance Function

Maintenance functions will be limited to and defined as follows:

*a. Inspect* To determine the serviceability of an item by comparing its physical, mechanical, and/or electrical characteristics with established standards through examination.

*b. Test* To verify serviceability and to detect incipient failure by measuring the mechanical or electrical characteristics of an item and comparing those characteristics with prescribed standards.

*c. Service.* Operations required periodically to keep an item in proper operating condition, i.e., to clean (decontaminate), to preserve, to drain, to paint, or to replenish fuel, lubricants, hydraulic fluids, or compressed air supplies.

*d. Adjust.* To maintain, within prescribed limits, by bringing into proper or exact position, or by setting the operating characteristics to the specified parameters.

*e. Align* To adjust specified variable elements of an item to bring about optimum or desired performance.

*f. Calibrate.* To determine and cause corrections to be made or to be adjusted on instruments or test measuring and diagnostic equipments used in precision measurement. Consists of comparisons of two instruments, one of which is a certified standard of known accuracy, to detect and adjust any discrepancy in the accuracy of the instrument being compared.

*g. Install* The act of emplacing, seating, or fixing into position an item, part, module (component or assembly) in a manner to allow the proper functioning of the equipment or system.

*h. Replace.* The act of substituting a serviceable like type part, subassembly, or module (component or assembly) for an unserviceable counterpart.

*i Repair.* The application of maintenance services (inspect, test, service, adjust, align, calibrate, replace) or other maintenance actions (welding, grinding, riveting, straightening, facing, remachining, or resurfacing) to restore serviceability to an item by correcting specific damage, fault, malfunction, or failure in a part, subassembly, module (component or assembly),

end item, or system. This function does not include the trial and error replacement of running spare type items such as fuses, lamps, or electron tubes.

*j. Overhaul.* That maintenance effort (service/action) necessary to restore an item to a completely serviceable/operational condition as prescribed by maintenance standards (i.e., DMWR) in appropriate technical publications. Overhaul is normally the highest degree of maintenance performed by the Army. Overhaul does not normally return an item to like new condition.

*k. Rebuild.* Consists of those services/actions necessary for the restoration of unserviceable equipment to a like new condition in accordance with original manufacturing standards. Rebuild is the highest degree of materiel maintenance applied to Army equipment. The rebuild operation includes the act of returning to zero those age measurements (hours, miles, etc.) considered in classifying Army equipments/components.

#### B-3. Column Entries

*a. Column 1, Group Number.* Column 1 lists group numbers, the purpose of which is to identify components, assemblies, subassemblies, and modules with the next higher assembly.

*b. Column 2, Component/Assembly.* Column 2 contains the noun names of components, assemblies, subassemblies, and modules for which maintenance is authorized.

*c. Column 3, Maintenance Functions.* Column 3 lists the functions to be performed on the item listed in column 2. When items are listed without maintenance functions, it is solely for purpose of having the group numbers in the MAC and RPSTL coincide.

*d. Column 4, Maintenance Category.* Column 4 specifies, by the listing of a "work time" figure in the appropriate subcolumn(s), the lowest level of maintenance authorized to perform the function listed in column 3. This figure represents the active time required to perform that maintenance function at the indicated category of maintenance. If the number or complexity of the tasks within the listed maintenance function vary at different maintenance categories, appropriate "work time" figures will be shown for each category. The number of task-hours specified by the "work time" figure represents the average time required to restore an item (assembly, subassembly, component, module, end item or system) to a serviceable condition under typical field operating conditions. This time includes preparation time, troubleshooting time, and quality

assurance/quality control time in addition to the time required to perform the specific tasks identified for the maintenance functions authorized in the maintenance allocation chart. Subcolumns of column 4 are as follows:

- C-Operator/Crew
- O-Organizational
- F-Direct Support
- H-General Support
- D-Depot

*e. Column 6, Tools and Equipment* Column 5 specifies by code, those common tool sets (not individual tools) and special tools, test, and support equipment required to perform the designated function.

*f. Column 6, Remarks.* Column 6 contains an alphabetic code which leads to the remark in section IV, Remarks, which is pertinent to the item opposite the particular code.

**B-4. Tool and Test Equipment Requirement (Section III).**

*a. Tool or Test Equipment Reference Code.* The numbers in this column coincide with the numbers used

in the tools and equipment column of the MAC. The numbers indicate the applicable tool or test equipment for the maintenance functions.

*b. Maintenance Category.* The codes in this column indicate the maintenance category allocated the tool or test equipment.

*c. Nomenclature.* This column lists the noun name and nomenclature of the tools and test equipment required to perform the maintenance functions.

*d. National/NATO Stock Number.* This column lists the National/NATO stock number of the specific tool or test equipment.

*e. Tool Number.* This column lists the manufacturer's part number of the tool followed by the Federal Supply Code for manufacturers (5-digit) in parentheses.

**B-5. Remarks (Section IV).**

*a. Reference Code.* This code refers to the appropriate item in section II, column 6.

*b. Remarks.* This column provides the required explanatory information necessary to clarify items appearing in section II.

(Next printed page is B-3)



SECTION II MAINTENANCE ALLOCATION CHART  
 FOR  
 MX-7778/GRC SUPPRESSOR ELECTRICAL

(1) GROUP NUMBER	(2) COMPONENT/ASSEMBLY	(3) MAINTENANCE FUNCTION	(4) MAINTENANCE CATEGORY					(5) TOOLS AND EQPT.	(6) REMARKS
			C	O	F	H	D		
00	SUPPRESSOR, ELECTRICAL TRANSIENT MX-7778/GRC	Inspect		0.1					A
		Service		0.25					B
		Install		1.0				3	
		Replace		0.5				3	
		Test			0.5			1,2	
01	CABLE ASSEMBLY SPECIAL PURPOSE CX-10613/G	Repair			1.0			4,5	
		Inspect		0.1					A
		Replace		0.25					
02	SUPPRESSOR, ELECTRICAL TRANSIENT MX-7777A/GRC	Repair			0.5			4,5	C
		Inspect		0.1					A
		Service		0.25					B
		Replace		0.5					
		Test			0.5			3	
		Repair			1.0			1,2	
		Repair				1.5		4,5	
		Overhaul					1.5	1,4,5 4,5,6	D D

SECTION III. TOOL AND TEST EQUIPMENT REQUIREMENTS  
FOR

MX-7778/GRC SUPPRESSOR ELECTRICAL

OOL OR TEST EQUIPMENT REF CODE	MAINTENANCE CATEGORY	NOMENCLATURE	NATIONAL/NATO STOCK NUMBER	TOOL NUMBER
1	F,H,D	POWER SUPPLY PP-1104C/G	6130-00-542-6385	
2	F,H,D	MULTIMETER ME-26/U	6625-00-360-2493	
3	O	TOOL KIT, ELECTRONIC EQUIPMENT TK-101/G	5180-00-064-5178	
4	F,H,D	TOOL KIT, ELECTRONIC EQUIPMENT TK-100/G	5180-00-605-0079	
5	F,H,D	TOOL KIT, ELECTRONIC EQUIPMENT TK-105/G	518 0-00-610-8177	
6	D	POWER SUPPLY (100VDC AND 100 AMPERES CAPACITY)		

SECTION IV. REMARKS  
 MX-7778/GRC SUPPRESSOR ELECTRICAL

REFERENCE CODE	REMARKS
A	Visual .
B	Clean, touch up paint.
C	Connectors only.
D	By parts replacement.



## APPENDIX C

### COMPONENTS OF END ITEM LIST

---

#### Section I. INTRODUCTION

##### C-1. Scope

This appendix lists integral components of and basic issue items for the MX-7778/GRC to help you inventory items required for safe and efficient operation.

##### C-2. General

This Components of End Item List is divided into the following sections:

*a. Section II. Integral Components of the End Item.* These items, when assembled, comprise the MX-7778/GRC and must accompany it whenever it is transferred or turned in. The illustrations will help you identify these items.

*b. Section III. Basic Issue Items.* These are the minimum essential items required to place the MX-7778/GRC in operation, to operate it, and to perform emergency repairs. Although shipped separately packed they must accompany the MX-7778/GRC during operation and whenever it is transferred between accountable officers. The illustrations will assist you with hard-to-identify items. This manual is your authority to requisition replacement BII, based on TOE/MTOE authorization of the end item.

##### C-3. Explanation of Columns

*a. Illustration.* This column is divided as follows:

(1) *Figure number.* Indicates the figure number of the illustration on which the item is shown.

(2) *Item number.* The number used to identify item called out in the illustration.

*b. National Stock Number.* Indicates the National stock number assigned to the item and which will be used for requisitioning.

*c. Description.* Indicates the Federal item name and, if required, a minimum description to identify the item. The part number indicates the primary number used by the manufacturer, which controls the design and characteristics of the item by means of its engineering drawings, specifications, standards, and inspection requirements to identify an item or range of items. Following the part number, the Federal Supply Code for Manufacturers (FSCM) is shown in parentheses.

*d. Location.* The physical location of each item listed is given in this column. The lists are designed to inventory all items in one area of the major item before moving on to an adjacent area.

*e. Usable on Code.* Not applicable. "USABLE ON" codes are included to help you identify which component items are used on the different models. Identification of the codes used in these lists are:

*f. Quantity Required (Qty Reqd).* This column lists the quantity of each item required for a complete major item.

*g. Quantity.* This column is left blank for use during an inventory. Under the Rcvd column, list the quantity you actually receive on your major item. The Date columns are for your use when you inventory the major item.

(Next printed page is C-3).



SECTION II INTEGRAL COMPONENTS OF END ITEM

(1) ILLUSTRATION		(2) NATIONAL STOCK NUMBER	(3) DESCRIPTION  PART NUMBER (FSCM)	(4) LOCATION	(5) USABLE ON CODE	(6) QTY REQD	(7) QUANTITY	
(A) FIG NO.	(B) ITEM NO.						RCVD	DATE
		5915-00-937-9577	SUPPRESSOR, ELECTRICAL TRANSIENT MX-7777A/GRC SM-C-632676 80063			1		
		5995-00-935-2551	CABLE ASSEMBLY, SPECIAL PURPOSE CX-10613/G SM-B-632694-2 80063			1		
		-----	INSTALLATION KIT SM-D-632654 80063			1		

SECTION III BASIC ISSUE ITEMS

(1) ILLUSTRATION		(2) NATIONAL STOCK NUMBER	(3) DESCRIPTION  PART NUMBER (FSCM)	(4) LOCATION	(5) USABLE ON CODE	(6) QTY REQD	(7) QUANTITY	
(A) FIG NO.	(B) ITEM NO.						RCVD	DATE
			TECHNICAL MANUAI TM 11-5915-223-12			1		



## APPENDIX E

### EXPENDABLE SUPPLIES AND MATERIALS LIST

---

#### Section I. INTRODUCTION

##### E-1. Scope

This appendix lists expendable supplies and materials you will need to operate and maintain the MX-7778/GRC. These items are authorized to you by CTA 50-970, Expendable Items (Except Medical, Class V, Repair Parts, and Heraldic Items).

##### E-2. Explanation of Columns

a. *Column 1 - Item Number.* This number is assigned to the entry in the listing and is referenced in the narrative instructions to identify the material (e.g., "Use cleaning compound, item 5, App. D").

b. *Column 2 - Level.* This column identifies the lowest level of maintenance that requires the listed item.

C - Operator/Crew

O - Organizational Maintenance

F - Direct Support Maintenance

H - General Support Maintenance

c. *Column 3 -National Stock Number.* This is the National stock number assigned to the item; use it to request or requisition the item.

d. *Column 4 -Description.* Indicates the Federal item name and, if required, a description to identify the item. The last line for each item indicates the part number followed by the Federal Supply Code for Manufacturer (FSCM) in parentheses, if applicable.

e. *Column 5 - Unit of Measure (UIM).* Indicates the measure used in performing the actual maintenance function. This measure is expressed by a two-character alphabetical abbreviation (e.g., ea, in, pr). If the unit of measure differs from the unit of issue, requisition the lowest unit of issue that will satisfy your requirements.

(Next printed page is E-3).



SECTION II EXPENDABLE SUPPLIES AND MATERIALS LIST

(1) ITEM NO.	(2) LEVEL	(3) NATIONAL STOCK NUMBER	(4) DESCRIPTION	(5) UNIT OF MEAS
		810-00-292-9625	PART NO. AND FSCM  TRICHLOROETHYLENE  FINE SANDPAPER NO. 000 OR 0000.  LINT-FREE CLEANING CLOTH	



By Order of the Secretary of the Army:

W. C. WESTMORELAND,  
General, United States Army,  
Chief of Staff.

Official

VERNE L. BOWERS,  
Major General United States Army,  
The Adjutant General

Distribution:

To be distributed in accordance with DA Form 12-51, organizational maintenance requirement AN/GRC-106, AN/PRC-25, AN/PRC-77, and AN/VRC-12 radio sets.

☆ U. S. GOVERNMENT PRINTING OFFICE : 1990 0 - 262-912 (30369)

